



CEILING

SYSTEMS

[Between us, ideas become reality.™]



i ceilings
SOUND SYSTEMS



Soundfield

Classroom Voice Reinforcement

SYSTEM INSTALLATION GUIDE



'Can they hear you at the back?'





i-ceilings Soundfield Systems provide a complete solution designed for use in teaching and training environments. They utilise the latest speaker and infrared technology to create sound reinforcement systems which combine the highest levels of performance and flexibility with the minimum of visual intrusion.

Please remember that Soundfield is a 'sound reinforcement' system, not a public address system; levels should therefore be set accordingly.



Typical Classroom Coverage:

Please note: These infrared Soundfield Systems are designed for use in a typical standard sized classroom (normally up to 30 pupils) and are not recommended for use in large room applications such as school halls, lecture theatres, sports halls, etc... .

(For larger applications, we suggest using RF wireless microphone systems).

The IR wireless microphones use direct/reflected light emissions and, so, large non-reflective surfaces (light absorbent surfaces such as black/dark painted walls or large fabric coverage, etc...) in the classroom which may reduce coverage must always be considered in the system's performance.

Installation of 2 wall sensors in a classroom:

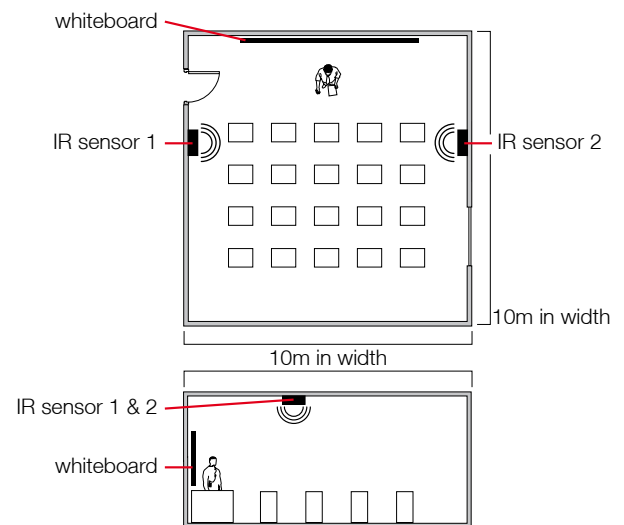

For further information on i-ceilings Soundfield Systems, please contact:

CIE-Group Ltd
Widdowson Close,
Blenheim Ind. Est.
Bulwell, Nottingham,
NG6 8WB, UK
T. +44(0) 115 977 0075
F. +44(0) 115 977 0081
E. iceilings@cie-group.com
W. www.cie-group.com

Should you need to clarify any details with regards to the product or its installation, please contact our technical support team on 0115 977 0075; we are always happy to provide help and technical advice.

⚠ Please read this manual carefully before starting the installation and ensure you have all the equipment required.

Soundfield Equipment Pack Lists

i-ceiling Soundfield Packs are supplied with the loudspeakers and infrared equipment in separate boxes.

Before going to site please check you have all the items required.

Detailed below are the contents lists for each of the various packs that are available...



• Soundfield Pack F

Pack A

1 x CS1000ME/AMP	Amplified Sound Panel Speaker
1 x APA/APL	CD/MP3/Laptop Wall Plate
1 x APA/TRAY	Equipment Support Tray
2 x 03284	Safety Cable
2 x 03518	Security Clip
1 x IWM-302	Infrared Belt Pack Transmitter
1 x IT-10+	Infrared Emitter/Microphone*
1 x IWR-220	Infrared Receiver
2 x IS-20A	Infrared Sensor
2 x EXT CABLE 10	10 Mtr Extension Cord for IS-20A
1 x HC-33	Drop-in Charger for IWM-302
2 x AA	Batteries for IWM-302
1 x IC-1/IC-2	Connecting Cables
2 x Instructions	Installation and Operation Manuals

Pack B

1 x CS1000ME/AMP	Amplified Panel Speaker
1 x CS1000ME	Sound Panel Speaker (slave)
1 x APA/APL	CD/MP3/Laptop Wall Plate
1 x APA/TRAY	Equipment Support Tray
2 x 03284	Safety Cable
2 x 03518	Security Clip
1 x IWM-302	Infrared Belt Pack Transmitter
1 x IT-10+	Infrared Emitter/Microphone*
1 x IWR-220	Infrared Receiver
2 x IS-20A	Infrared Sensor
2 x EXT CABLE	10 Mtr Extension Cord for IS-20A
1 x HC-33	Drop-in Charger for IWM-302
2 x AA	Batteries for IWM-302
2 x Instructions	Installation and Operation Manuals

Pack C

1 x PRO PANEL/AMP	Amplified Pro Sound Panel Speaker
1 x APA/APL	CD/MP3/Laptop Wall Plate
1 x APA/TRAY	Equipment Support Tray
2 x 03284	Safety Cable
2 x 03518	Security Clip
1 x IWM-302	Infrared Belt Pack Transmitter
1 x IT-10+	Infrared Emitter/Microphone*
1 x IWR-220	Infrared Receiver
2 x IS-20A	Infrared Sensor
2 x EXT CABLE 10	10 Mtr Extension Cord for IS-20A
1 x HC-33	Charger for IWM-302
2 x AA	Batteries for IWM-302
1 x IC-1/IC-2	Connecting Cables
2 x Instructions	Installation and Operation Manuals

Pack F

4 x FBT Studio 2	Wallmount Loudspeakers
1 x IRX	Wallmount Amplifier/IR Receiver
4 x 03284	Safety Cable
1 x IWM-302	Infrared Belt Pack Transmitter
1 x IT-10+	Infrared Emitter/Microphone*
2 x IS-20A	Infrared Sensor
3 x EXT CABLE 10	10 Mtr Extension Cord for IS-20A
1 x HC-33	Charger for IWM-302
2 x AA	Batteries for IWM-302
1 x AV15276	Phono Coupler
2 x Instructions	Installation and Operation Manuals

*NB. An MC-72X Head Worn Microphone or MC75X/SL Collar Microphone may have been specified in place of the IT-10+ emitter/microphone. In this case the emitter is an IT-11X and the microphone is listed separately.

- IS-20A Extra Infrared Sensor



- Ext. cable 10 10 Metre IR Sensor Extension Lead



- IWH-301A Handheld Transmitter/Microphone



- 7W1B2V4 Rechargeable Battery for IWH-301A



- APA/APL CD/MP3/Laptop Wall Plate



- APA/LLO Radio Assisted Hearing Aid Output Plate



Safety Note

It is essential that all equipment mounting trays and safety bonds (safety cable & security clips) are used and installed correctly.

Infrared Wireless Microphone Technology

This manual is intended for use by installation engineers. The separate user manual should be left with the user.

Infrared Wireless Microphone Technology:

As the Systems use wireless infrared to transmit the user's voice, some understanding of how this operates is useful...

Infrared is simply invisible light and acts in a very similar way to ordinary light, a useful feature in classroom applications. For example, infrared recognises walls as boundaries so multiple systems can be used without problems.

Whilst it is true that IR can be directional, all our emitters use high power LED arrays and detectors are wide angle. Infrared also readily reflects from walls, ceilings and windows so full coverage is easily achievable. Frequency allocation problems are eliminated and any transmitter can be used with any receiver; as a result these systems are both easy to commission and very flexible in use.



AC Power Requirements:

Pack A, B, and C Systems:

A single 13 amp power point is all that is required as all ancillary Soundfield system items are powered directly from the panel amplifier. If two speakers are required, a further slave Sound Panel (set to 8 ohms) can be connected to the extension speaker terminals of the Panel Amp (see page 10 for connection details).

Pack F Wallmount System:

A single 13 amp power point is all that is required as all ancillary items are powered from the IRX.



Cable Requirements:

Mains & Audio:

All mains supply cables (terminated with 13 amp UK plugs) are included with kits, as are the interconnection cables between the infrared receiver and amplifier.

Infrared Receiver and External Detectors:

Two ready-terminated 10 metre coaxial extension cables are provided for the connection of the extension IS-20A infrared detectors. If required, these can be extended to 20 metres by means of a further extension cable and male-to-male coupler. (The Pack F System is supplied with 3 extension cables and a male-to-male coupler). For distances of over 20 metres please consult our technical support team.



Outreach Input Plates

A maximum of 5 Outreach Plates can be used with the i-ceilings amplified Sound Panel or IRX Wallmount Amplifier. The APA/APL (supplied with the packs) is intended to be used for the connection of a laptop, CD, MP3 player (or similar audio signal) and should be located in a convenient position near to the teaching position.

Outreach Plates are active with balanced outputs and, as such, can be daisy-chained together to provide multiple inputs as required, each with its own dedicated volume control. By this means it is possible to provide a flexible input structure to cater for almost any conceivable requirement.

Low Level Output Plates (APA/LLO):

These optional units are intended to facilitate the connection of individual hearing assistance systems to the Soundfield system. The plate is supplied with a 3.5mm 2pole jack socket with an output level of 775volts nominal, set by means of a user adjustable level control.

Cable requirements are as Outreach input plates, but a separate cable **must** be provided where this facility is installed.

All Outreach input and output plates require a single gang socket box with a minimum depth of 25mm.



- APA/APL Outreach Plate for AV inputs



- APA/LLO Outreach Plate for assistive hearing systems

Outreach Plate connection cable specification:

The cable between the speaker panel, the first and any following Outreach Plates **must be to the following minimum specification:** 1 pair twisted and screened for audio, plus 1 additional pair for power. 'West Penn' 357 supplied by CIE-Group, or any good quality quad microphone cable should be suitable.

A wide range of Outreach Plates to suit various other interface requirements is available; please call CIE-Group for details.

Sound Panel Loudspeaker Installation

Sound Panel Loudspeaker positioning and installation (Packs A & C):

In systems using only one i-ceilings CS1000 or Pro Panel, the speaker unit should ideally be installed in the ceiling grid slightly to the rear of the classroom using the teaching position as a datum and as near as possible to the centre line of the other axis (see **Diagram 1**).

(Pack B):

When 2 panels are used, the exact positioning will be dictated by the shape of the classroom but the locations should be chosen to give the best possible coverage.

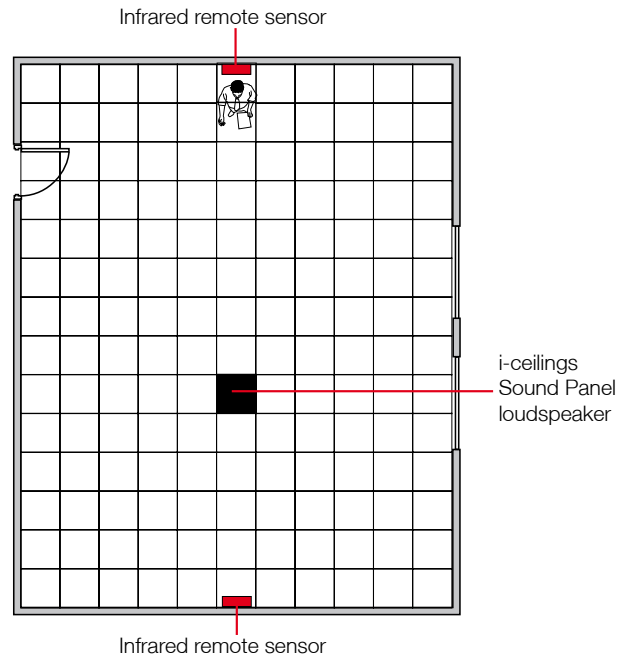

• Diagram 1

Sound Panel Cabling:

Take care to route all cables in such a way that they cannot rest on the rear of the Sound Panel.

When completing the installation be sure to fit the safety bonding wire to each speaker.

Finally check that no debris has been dropped on the panel. Remove everything; you would be amazed at the effect a 10mm cable off-cut can produce!

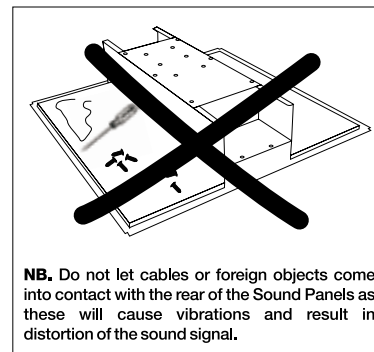

Remote Infrared Sensor (IS-20A) installation:

Two remote IR sensors are supplied with all kits. These should be installed at either end of the classroom just below ceiling level. Generally the centre of the wall behind the teaching position and the same position on the opposite wall will give the best coverage (see **Diagram1 above**) (alternatively position on opposite sides of the room).

The IS-20A is a 170 degree wide angle detector and should be angled slightly downwards to give the best possible coverage.



ceilings

Conventional Wall Speaker Positioning



Where FBT Studio2 Loudspeaker option is used (Pack F): If possible, the 4 speakers should be installed in Position 1 as shown in **Diagram 2.1**; if this is not possible then Position 2 shown in **Diagram 2.2** can be used.

Before installation the rotary switch at the rear of the speakers must be set to 4Ω. Do not attempt to run the speakers at higher power settings or at low impedance as this will damage the amplifier.



Safety Note

It is most important that the supplied safety cables and security clips are used and fitted correctly on each loudspeaker as part of the installation.

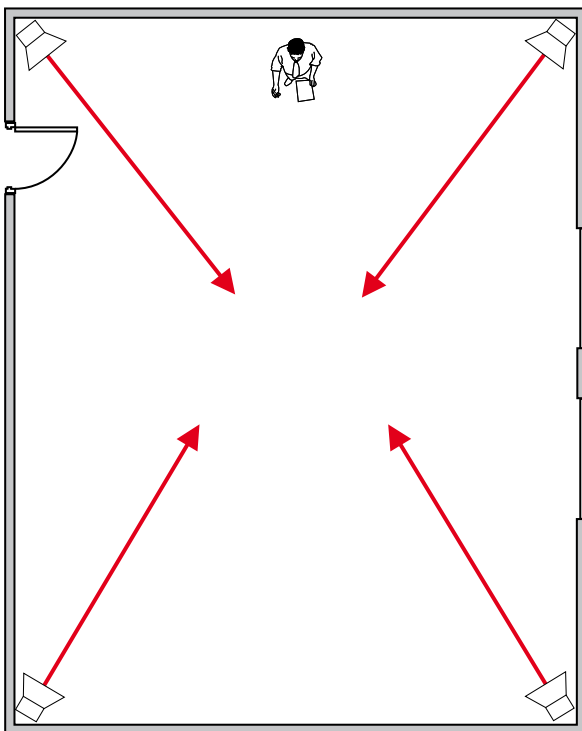

• **Diagram 2.1 – FBT wall speaker Position 1**

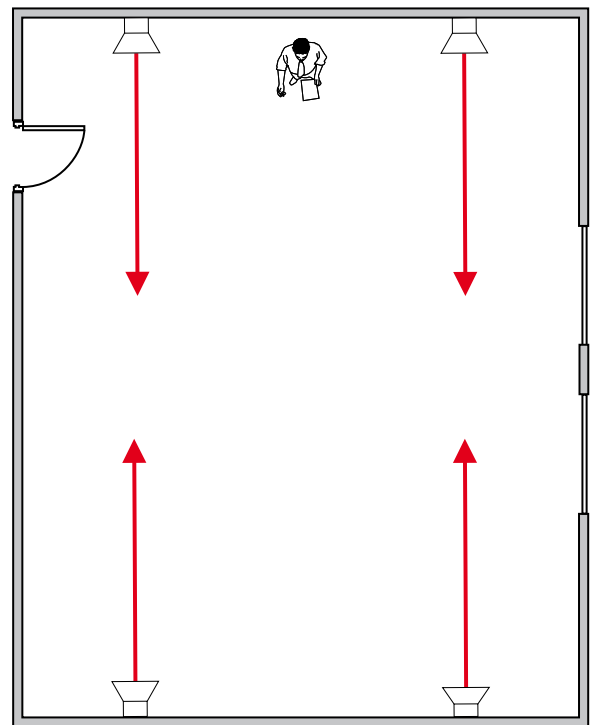

• **Diagram 2.2 – FBT wall speaker Position 2**

IRX Wallmount Amplifier/IR Receiver

When an Armstrong CS1000 or Pro Panel is used, the amplifier is an integral part. It supplies power to the IR receiver and any Outreach points as well as providing audio inputs and controls; please refer to IAPA section for details on connection and commissioning.

However, where conventional wall speakers (Pack F) are used, the IRX Wallmount Amplifier/IR Receiver is provided as part of the kit. It should be installed adjacent to the whiteboard (or front of the classroom) at a height convenient to allow adjustment of the level controls. The associated Outreach Plate should also be installed close by.

Please refer to page 12 for details of IRX installation and commissioning.



IAPA Integrated Panel Amplifier

Introduction:

The IAPA (Integrated Armstrong Panel Amplifier) consists of a 20W power amplifier pre-installed on an Armstrong i-ceilings Sound Panel. Sound Panels can be supplied with a wide range of ceiling finishes allowing the unit to be installed in any Armstrong suspended ceiling.

For advice on matching non-Armstrong suspended ceilings, please contact the CIE-Group sales team.



IAPA Features:

The IAPA amplifier has two inputs; one is at line level allowing the use of remote Outreach input plates such as the APA/APL, the other input is at a level suitable for connection to a Chiayo IWR220 (or similar infrared or RF wireless microphone receiver). An 18v DC supply is available from the amplifier to drive the Outreach plates and a 15v DC supply to power the IR receiver. Both inputs have their own level controls.

An additional line level output, 18v DC supply and external low impedance speaker output are also features of this unit.

The unit is fitted with 'High' and 'Low' tone controls to allow adjustment of the frequency response of the panel. The frequencies at which the controls operate have been chosen to allow speech clarity to be optimised to the acoustic environment.

All the connections to the unit are externally accessible and are of the removable screw terminal type, allowing for quick and easy connection.

IAPA Specifications:

Rated Output:	20W RMS into 8 ohms
Frequency Response:	100Hz ~ 18kHz \pm 3dB
THD (At 1kHz):	Better than 0.1% at rated output
Tone Controls:	Low 1kHz \pm 12db High 10kHz \pm 12db
Line Input:	500mv, 600 Ohm balanced
Mic. Input:	200mv, 10k Ohm unbalanced
18v Output:	18v DC, fused at 100mA max.
15v Output:	15v DC, fused at 500mA max.
Line Output:	750mV, 600 Ohm Balanced
Power Consumption:	35W max.
Power Input:	230v AC 50Hz via IEC socket
Case:	White painted steel

IAPA Connection Details:
(refer to Diagram 3 on page 11)

- **Line In:**

Balanced line level input terminals for connection of up to five remote Outreach Input plates (APA/APL, etc).

- **Mic Rcvr In:**

Unbalanced microphone level input terminals for connection of a Chiayo IWR-220 infrared wireless microphone receiver. It is also possible to use this input to connect Chiayo RF radio microphone receivers. Contact CIE-Group Technical Support (0115 977 0075) for advice.

- **18v DC Out (Line Level / Line Sig Out):**

18v DC supply terminals providing power to the Outreach plates. These terminals will provide a combined maximum output current of 100mA.

- **15v DC Out: (Mic Rcvr)**

15v DC supply terminals providing power to the IWR-220 receiver only. These terminals will provide a combined maximum output current of 500mA.

- **Line Output:**

Balanced line level output terminals available on the IAPA for connection to the line level input of other equipment such as the APA/LLO Outreach plate or Induction Loop amplifiers. These can be used for connecting multiple i-ceilings panels in larger rooms where one speaker would not give sufficient sound coverage.

- **Ext Spkr:**

External 8 ohm speaker terminals for powering a single additional Armstrong CS1000 or Pro series panel. Note: damage to the amplifier will occur if speakers with a total impedance of less than 8 ohms are connected to these terminals.

- **Mains In:**

The mains input should be connected using an IEC type connector. The supply input should be 230V AC ($\pm 10\%$) 50Hz.



Warning

No connections should be made to the unit whilst the mains power is connected

Diagram 3 - IAPA Connection Details

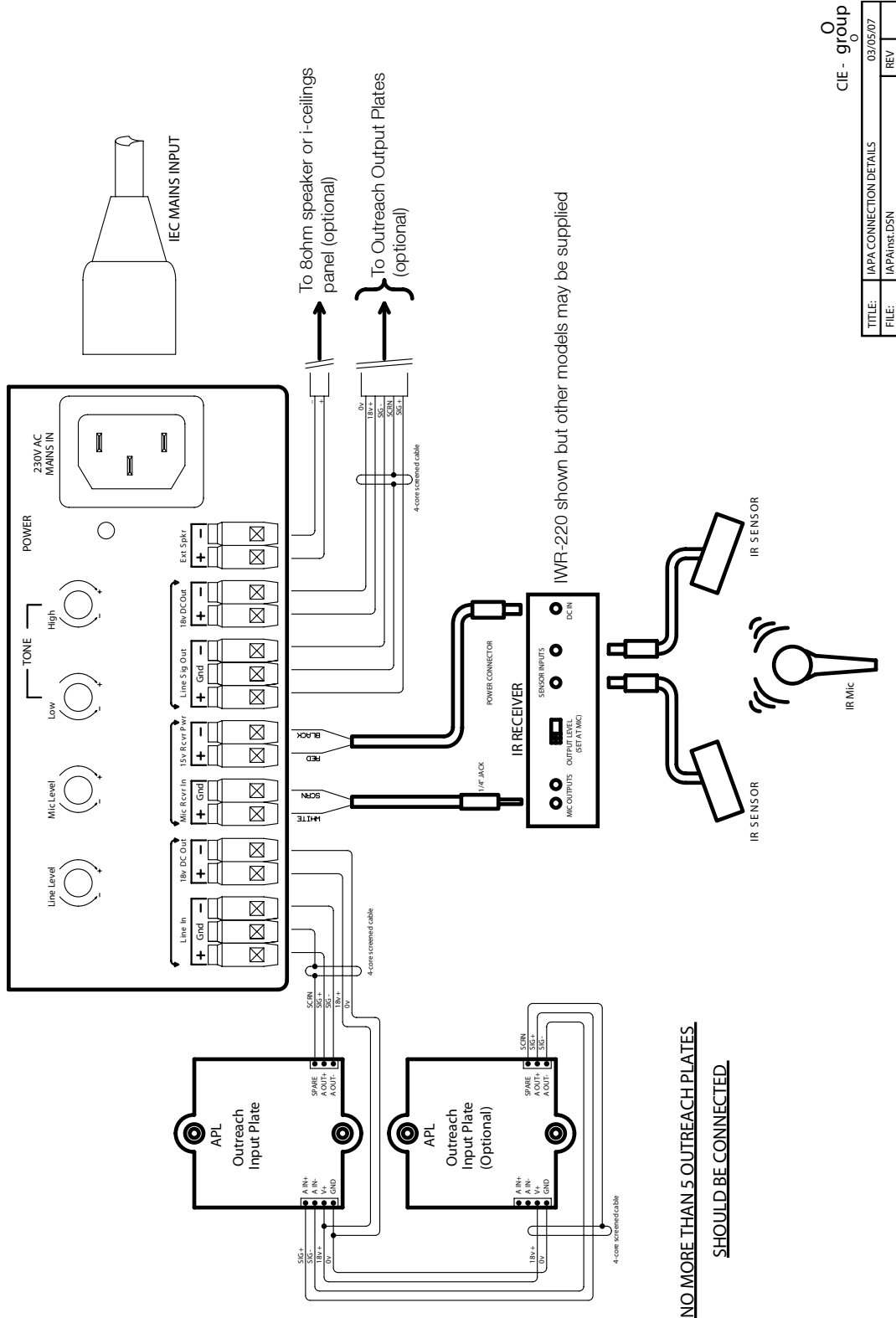

CIE - group

TITLE:	IAPA CONNECTION DETAILS	03/05/07
FILE:	IAPAInst.DSN	REV



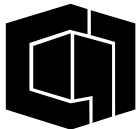

Clever Little Box.

IRX Wallmount Amplifier/IR Receiver

The IRX unit is a wallmount system featuring 20W amplifier and in-built infrared receiver, developed specifically for Soundfield systems using conventional wallmount loudspeakers.

It has been designed to be both user-friendly in the classroom, whilst ensuring complete safety and security in such a welfare-critical environment.

The in-built amplifier features two inputs; one is at line level allowing the use of remote Outreach input plates such as the APA/APL, the other input controls the level of the internal infrared microphone receiver. An 18v DC supply is available from the amplifier to drive the Outreach plates. Both inputs have their own level control.

The amplifier also includes low impedance loudspeaker output (minimum impedance 4ohms) and a separate line level output and 18v DC supply for use with optional APA/LLO output plate.

The IRX is fitted with high and low tone controls to allow adjustment of the frequency response of the speakers. Frequencies at which the controls operate have been chosen to allow speech clarity to be optimised to the acoustic environment.

All signal connections to the unit are accessible only when the front cover is removed and are of the removable screw terminal type allowing for quick and easy connection.

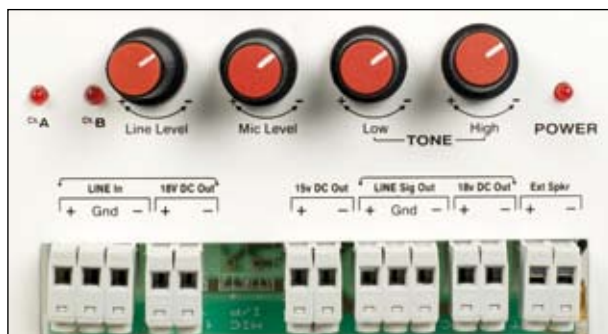

IRX Specifications

Rated Output:	20W RMS into 8 ohms
Frequency Response:	100Hz ~ 18kHz \pm 3dB
THD (At 1kHz):	Better than 0.1% at rated output
Tone Controls:	Low 1kHz \pm 12dB, High 10kHz \pm 12dB
Line Input:	500mv, 600 ohms balanced
18V Output:	18V DC, fused at 100mA
15V Output:	15V DC, fused at 500mA
Line Output:	750mv, 600 ohms balanced
Power Consumption:	35W max
Power Input:	230V AC 50Hz via IEC socket
Case:	Grey painted steel
Weight:	4.5 kg
Dimensions:	325(H) x 224(W) x 85(D) mm



Warning

No connections should be made to the unit whilst the mains power is connected

For Connection Details:

(refer also to Diagram 4 opposite)

- **Line In:**

Balanced line level input terminals for connection of up to five remote Outreach input plates (APA/APL etc).

- **18v DC Out (Line Level/Line Sig Out):**

18v DC supply terminals providing power to the Outreach plates. These terminals will provide a combined maximum output current of 100mA.

- **15v DC Out:**

15v DC supply terminals will provide a combined maximum output current of 500mA and can be used to power a HC-33 Charger.

- **Line Output:**

Balanced line level output terminals for connection to the line level input of other equipment such as the APA/LLO output plate or Loop amplifiers.

- **Ext Spkr:**

External Speaker terminals for powering up to 4 FBT Studio 2 loudspeakers set at low impedance. **Important note: the speakers need to be wired in series parallel (see diagram 4).** Damage to the amplifier will occur if speakers with a total impedance of less than 4 ohms are connected to these terminals.

Diagram 4

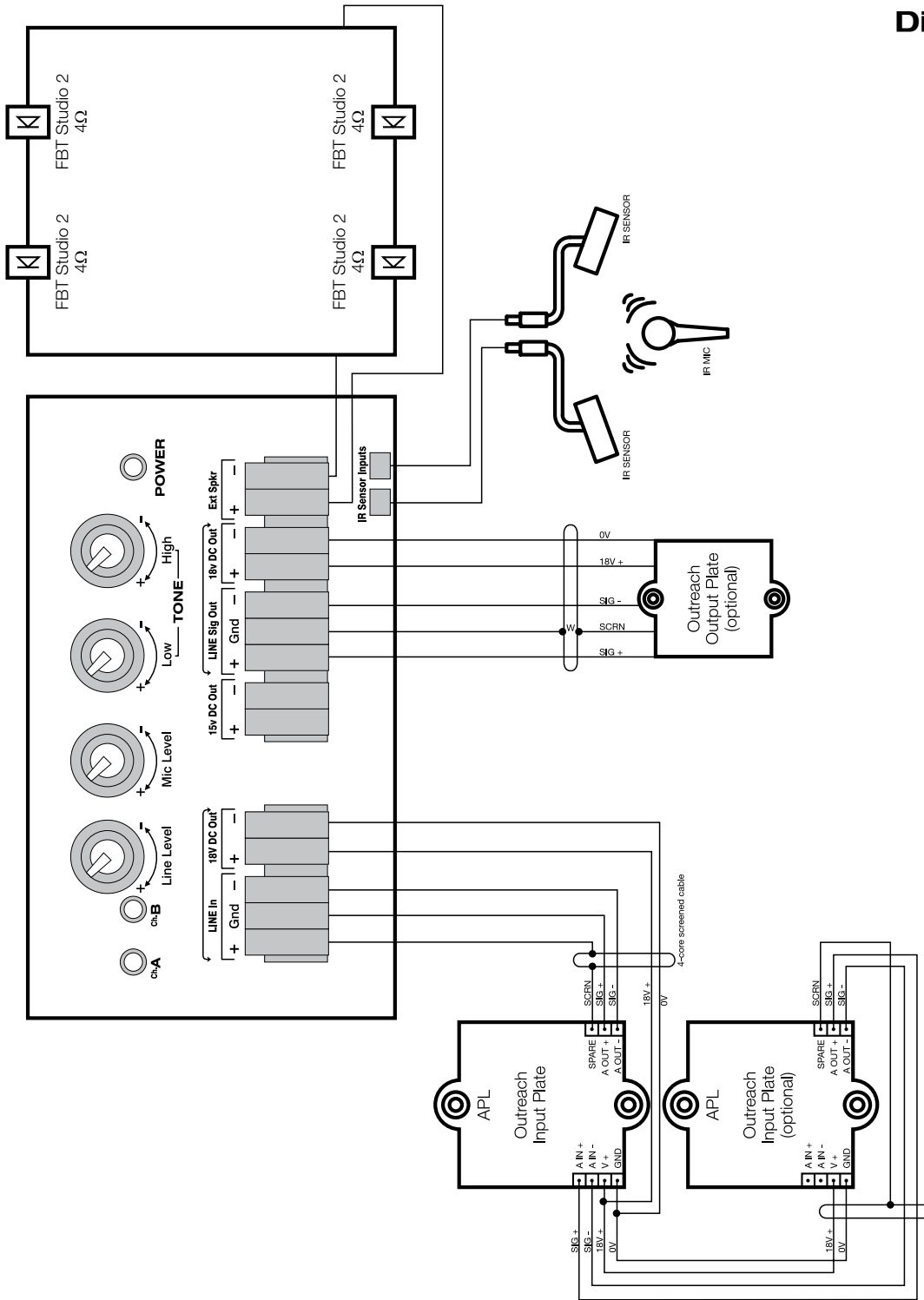

NO MORE THAN 5 OUTREACH PLATES SHOULD BE CONNECTED



Red button and clear plastic cover

Mains Power Connection & Power Switch

The IRX is supplied with a mains cable featuring a tamper-proof IEC plug which once inserted into the mains socket is purposely very difficult to remove and avoids accidental disconnection of power.

Note: If the mains cable needs to be disconnected from the IRX unit, break the clear plastic cover on the red button of the rear of the IEC plug, then depress the red button to release. The IRX Power Switch is positioned on the bottom of the unit, adjacent to the IEC socket.

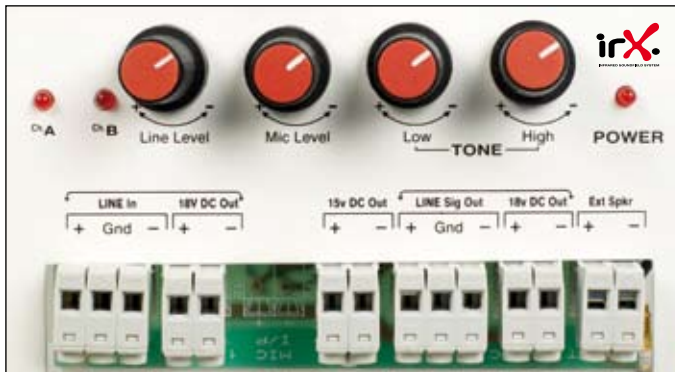

- IRX Wallmount Amplifier/IR Receiver controls and connectors

Packs A, B, C & D:

Before testing the system, ensure that all the batteries required for the transmitters are fully charged.

After checking all the connections and wiring, set the line and mic level controls to the half way point then connect the unit to the mains supply.

The Power LED on the amplifier (of either a Panel Amplifier or the IRX) will illuminate together with the green LEDs on any Outreach plates fitted. (If the green LEDs fail to illuminate, disconnect the supply and check the connections to the Outreach plates are correct.)



- i-ceilings Powered Sound Panel controls and connectors

For Packs A, B and C **only**:

Set output level switch on the IWR-220 to MIC and switch the Receiver on; the red LED on the front panel should illuminate together with those fitted to the external IR sensors. The fixed equipment should now be operating.

Next test the APA/APL input plate(s) by feeding in a low level signal from a music source such as a CD, MP3 or laptop. Set the volume control on the plate to maximum then adjust the line input on the Sound Panel amplifier or IRX to produce a reasonable level over the room.

Remember a Soundfield System is not a PA system - the objective is to provide a comfortable listening level over the entire room. In an empty room the system needs to be set slightly louder than would normally be required. Do not try to adjust the tone controls at this point.

If more than one plate of the same type has been installed, all should be tested using the same method. If different type Outreach plates have been installed, each should be tested using a suitable input source.

Now set up and test the infrared microphone transmitters using the procedures on pages 15 and 16. If the system includes an IWH-301 hand mic as well as a IWM-302 beltack, then set the hand mic first.

Setting the Transmitter(s)



- IWM-302 Beltpack Transmitter and IR emitter

IWM-302 Beltpack Transmitter with IT-10+ or IT-11x

Install 2 fully charged batteries into the beltpack. If you don't have any fully charged batteries use Hi capacity AA cells for the test.

Using a miniature screwdriver, carefully set the LO-HI switch to low. This setting will be adequate in most applications and results in longer battery life before recharging is required.

Now set the channel A or B, the IR Receiver will receive both. Where a single transmitter is installed, use channel A. The maximum number of transmitters that can be used in the same room is two.

Remember infrared does not pass through walls so interference to or from adjacent room systems need not be considered.

Plug the emitter into the beltpack, the IT-10+ and IT-11x are identical except for the type of microphone. The IT-10+ has a built-in lapel-type microphone, whilst the IT-11x has a socket to connect a collar or headworn microphone. Note the plugs on the emitters are 5 pin whilst the plugs on the microphones are 4 to ensure a microphone cannot be plugged directly into the beltpack.

Set the beltpack volume control to minimum and switch the beltpack on. Ensure the emitter can see the sensors. One of the channel LEDs on the Receiver should illuminate and audio should be heard from the speaker as the volume control is advanced.



- IT-10+ featuring built-in lapel microphone



- IT-11x featuring socket for collar or headworn microphone

Setting the Microphone level:

With the Microphone Level Control set to mid way, advance the volume control on the beltpack to maximum; if feedback occurs before the maximum is reached, reduce the gain by means of the internal MT gain control on beltpack (see photo).

If full volume is reached without feedback, increase the Microphone level on the Sound Panel or IRX amplifier until feedback is just audible then reduce level back by one point. In an empty classroom this should be approximately the correct volume.



IWH-301 Handheld Microphone:

The IWH-301 is fixed frequency and will have been supplied on either channel A or channel B, which cannot be changed on site. With exception of the on/off switch, this microphone has no user or installer adjustable controls.

Fit the battery, which is a special type Part Number 7W1B2V4. The IWH-301 is not designed to take AA size batteries.

The microphone level should be set using the following method:

With the microphone switched on, advance the Level Control on the Amplifier until feedback occurs, then reduce the level slightly. In an empty classroom this should be about the right volume.



Checking the infrared coverage:

When the transmitters and detectors used on the installation have been set, check the infrared coverage in the teaching space or training room.

Whilst the infrared is, in theory, line of site it readily reflects off many surfaces (emitting power has also increased significantly in line with improvements in LED technology). Provided the two sensors are installed and angled correctly, and the transmitter batteries are charged completely, coverage of all areas likely to be used by the teacher should be readily achieved. If this is not the case the sensors should be checked.

Firstly ensure that the red LEDs are illuminated on both IS-20A sensors. Secondly test each individual sensor, preferably by substitution or, if a replacement is not available, by disconnecting each sensor in turn. The coverage with a single sensor should be distinctly poorer; if no change is observed suspect the sensors.

Please note complete coverage is unlikely to be achieved with only a single sensor.

Chargers and Batteries:

Both transmitter types are designed to use NiMH (Nickel Metal Hydride) batteries, the IWH-302 requires 2 AA size of 2300mAh capacity whilst the IWH-301 uses a non-standard size with a capacity of 2100mAh. Replacements are best obtained from CIE-Group.

The IWH-302 and IWH-301 both use the HC-33 universal drop-in charger. Charging (which takes place automatically) is indicated by a red LED, fully-charged batteries are indicated by a green LED. Both units are designed to use NiMH batteries which do not suffer from memory, offer a higher capacity than NiCd cells and are environmentally friendly. They need much the same care as NiCd types, though they need only to be run down every week or two, if they are charged every night.

Please note that most rechargeable batteries recharge to 50% full in just a few minutes. However, to achieve 100% recharge requires significantly longer. The most effective method of achieving 100% recharge is by charging over night.

Note: Before charging either transmitter, please ensure that the batteries are installed the correct way around (pos-pos/neg-neg). Inserting the batteries the wrong way around will result in failure of/damage to the microphone transmitter. This is not covered under warranty.

Please demonstrate the equipment to the user and explain all the features and facilities. Make sure the user understands the charging and care of batteries. Finally leave the user manual with them, together with details of who to contact if service is required.



www.soundfield.uk.com

For further details on the i-ceilings Soundfield product range, its use and benefits in the classroom, please visit us online at: www.soundfield.uk.com

Product compliance:

These products comply with the following European directives:

- EMC directive 89/336/EC (plus amendments)
- Low voltage directive 72/23/EC (plus amendments)
- WEEE Directive 2002/95/IEC
- RoHS Directive

Disposal:

When this product has reached the end of its useful life it must be disposed of in accordance with the European Parliament and Council Directive on Waste Electrical and Electronic Equipment (2002/96/EC) ('the WEEE Directive')

For disposal details, please go on-line to www.iceilings.uk.com/weee.htm



ceilings

'SoundField' or a 'SoundField Voice Reinforcement System' is essentially the integration of a 'mini-PA system' in the classroom.

Under quiet classroom conditions, most teachers have enough natural volume in their voice to communicate effectively with a standard sized class. However, a number of acoustic factors (lively/noisy classes, reverberant room conditions, ambient noise from equipment outside, hearing difficulties, etc...) can have a significant effect on clear, effective teacher/pupil communication.

The inclusion of a SoundField System in the classroom will raise the teacher's voice above this ambient noise level, to give even voice coverage throughout the room and without the need to shout or raise one's voice.



schools



colleges



universities



training centres

Approved Supplier:

An exclusive partnership between Armstrong World Industries and CIE-Group Ltd.