

SOUND PANELS PRO SERIES/CS-1000
PROCESSORS A2001/D2001
AMPLIFIER D4100



▲ Rear view of Pro Series sound panel



▲ Processors A2001/D2001



▲ Amplifier D4100



Sound panel in an Optima ceiling. The speaker is invisible!

- Applications :
- Office
 - Healthcare
 - Retail
 - Hospitality
 - Education
 - Transportation

Sound panels:

- ceiling panel speaker with superior combined performance for music, public address, voice alarm and active acoustics that enhance privacy, comfort and workspace effectiveness,
- available to coordinate with Armstrong's most popular ceiling patterns, for retrofit as well as new constructions.



▲ Orcal



▲ Ultima/Optima

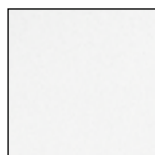

▲ Dune



▲ Fine Fissured



▲ Tatra



▲ Cortega

SOUND PANELS PRO SERIES/CS-1000

Loudspeaker features

	PRO SERIES	CS-1000
GENERAL		
Invisible, flat panel loudspeaker	•	•
Exclusive system diffusing foreground music/ PA*/voice alarm through the same speaker	•	
Exclusive system diffusing background music/ PA*/voice alarm/active acoustics through the same speaker		•
Compatible with standard commercial sound systems	•	•
Pre-fitted 2 pin connectors provide for a simple system setup	•	
Fire dome option	•	•
TECHNICAL		
Compatible with 100 V line systems as well as low impedance systems (8 Ohms by-pass)	•	•
No phase distortion effects	•	•
Sound level decay, as a function of loudspeaker/ listener distance is lesser that with cone speakers	•	•
MUSIC / PA* / VOICE ALARM		
Improved intelligibility	•	•
Feedback effects are significantly reduced	•	•
Full range flat panel loudspeaker	•	•
Reduced installation costs: faster installation without cutting holes in the ceiling tiles	•	•
Improved coverage means fewer speakers required / m ²	•	•
ACTIVE ACOUSTICS (SOUND MASKING)		
Exclusive sound masking system with direct sound diffusion in the working environment		•
Achieve designed levels of confidentiality		•
Complete acoustical solution for more effective workspaces		•

Range

PRO SERIES	
Pro Series Ultima / Optima MicroLook 600 x 600 mm	BP6013M
Pro Series Ultima / Optima Tegular 600 x 600 mm	BP6014M
Pro Series Dune Plus MicroLook 600 x 600 mm	BP6015M
Pro Series Dune Plus Tegular 600 x 600 mm	BP6016M
CS-1000	
CS-1000 Ultima / Optima MicroLook 600 x 600 mm	BP6017M
CS-1000 Ultima / Optima Tegular 600 x 600 mm	BP6018M
CS-1000 Dune Plus MicroLook 600 x 600 mm	BP6019M
CS-1000 Dune Plus Tegular 600 x 600 mm	BP6020M
CS-1000 Fine Fissured MicroLook 600 x 600 mm	BP6021M
CS-1000 Fine Fissured Tegular 600 x 600 mm	BP6022M
CS-1000 Cortega MicroLook 600 x 600 mm	BP6023M
CS-1000 Cortega Tegular 600 x 600 mm	BP6024M
CS-1000 Tatra MicroLook 600 x 600 mm	BP6025M
CS-1000 Tatra Tegular 600 x 600 mm	BP6026M

Description

PRO SERIES

Material: steel frame, special honeycomb membrane, glass painted scrim facing
 Dimensions: 600 x 600 x 110 mm
 Panel weight: 4.5 Kg per panel
 Shipping weight: 11 Kg/carton (1 carton = 2 panels)
 Warranty: three-year limited warranty on materials and workmanship from date of manufacture*

CS-1000

Material: steel frame, specially designed tubular membrane, glass painted scrim facing
 Dimensions: 600 x 600 x 64 mm
 Panel weight: 3.10 Kg per panel
 Shipping weight: 8.0 Kg/carton (1 carton = 2 panels)
 Warranty: three-year limited warranty on materials and workmanship from date of manufacture*

* Sales of the product and liability are in accordance with the terms and conditions of sale

Speaker data

PRO SERIES	CS-1000
Sensitivity: 87 dB @ 1 W, 1 meter	Sensitivity: 82 dB @ 1 W, 1 meter
Taps: 100 V: 7.5, 15, 30 W 8 Ohms By-pass	Taps: 100 V: 1/4, 1/2, 1, 2, 4, 8 W 8 Ohms By-pass
Transducers: 2	Transducer: 1
Power Capacity: 30 W	Power Capacity: 8 W

Frequency response

CS-1000 & Pro series frequency response

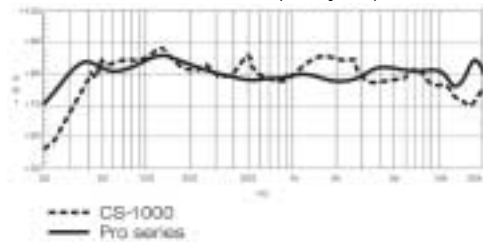

How to specify?

PRO SERIES / CS-1000

The loudspeaker shall be a full range device producing frequencies from 70 Hz to 18 KHz (100 Hz to 18 KHz for the CS-1000). Total radiating surface shall be 0,3 m². Frequency dispersion shall be 180° up to 16 Kz. The loudspeaker shall have a sensitivity of 87 dB 1 W/1 M (82 dB for the CS-1000) with a power rating of 30 W RMS (8 W RMS for the CS-1000). The loudspeaker shall have an exterior frame constructed of steel, measuring 600 x 600 mm. The depth of the loudspeaker shall be no more than 110 mm (64 mm for the CS-1000). The unit shall weight no more than 4,5 Kg (3,1 Kg for the CS-1000). The loudspeaker shall be i-ceilings Pro series (CS-1000) sound panel.

PROCESSORS A2001/D2001

A2001/D2001, analogue and digital output processors:

- DSP-based, software-controlled processors, manage and enhance a unique combination of music, public address and active acoustics
- ability to interconnect with other processors to accommodate current and future needs
- compatible with standard commercial sound systems
- fast, easy system setup with remote monitoring via the A2D2 graphic interface

Product features	Music features									
<ul style="list-style-type: none"> - Eight audio program sources; six external inputs: public address (Telco), microphone, analog and digital music, and two internal uncorrelated noise sources - Eight independent outputs – each with digital 28-band 1/3 octave equalization - RS232 port for system setup - RS232 port for remote control interfacing with various commercially available control systems - Balanced connections via industry-standard two-part connectors - Tamper proof operation - Non-volatile memory for all system settings - Remote level control by DTMF (touch tone) telephone - Gating and soft-knee limiting on Telco and microphone inputs - Universal power 90-240 VAC, 50-60 Hz autoswitching - Two U rack-mountable - CE marking 	<ul style="list-style-type: none"> - Two analog IHF music inputs - Two analog line level / one stereo digital coaxial S/PDIF inputs - Baxandall tone controls on all music inputs 									
	Public address features									
<p>Specifications</p> <p>Frequency Response: Microphone input: 80/120 Hz to 18 KHz Music input: 50 Hz to 18 KHz Line input: 50 Hz to 18 KHz Telco input: 250 Hz to 4 KHz</p> <p>Distorsion: THD better than 0.02 % @ 1 KHz</p> <p>Dynamic Range: 100 dB</p> <p>Input Impedances: Microphone: > 2k Ohms Music/Line: > 10k Ohms Telco: 600 Ohms nominal</p> <p>Levels: Nominal operating level: 0 dBv Maximum input levels: Microphone -10 dBv Music +6 dBv Line +20 dBv</p> <p>Analog output (A2001): Nominal output level: 0 dBv [Balanced] less than 100 Ohms Maximum output level: +20 dBv</p> <p>Digital output (D2001): AES-EBU Standard on proprietary cable interface</p> <p>Noise Sources: Peak to average ratio: 8 dB A/D and D/A Converters: 24-bit Sigma Delta Crosstalk: Better than -80 dB @ 1 KHz Power: 35 VA</p>	<ul style="list-style-type: none"> - Five priority levels for public address - Two band shelving and two band parametric equalization for microphone input - Two band shelving and two band parametric equalization for Telco input - Selectable music and line ducking / muting by public address - Compatible with most PBX products, and easily ties to KTS and Centrex systems - Highly flexible public address interface with 99 DTMF codes that can be customized many ways - Multiple units linkable - OPX port for off-premises bi-directional linking of systems - Multiple confirmation tones - "Mute all" contact closure for fire and like safety control 									
	Active acoustics features									
	<ul style="list-style-type: none"> - Customized noise spectrum for optimised performance - Dual uncorrelated digital noise sources to provide uniform spatial distribution: <ul style="list-style-type: none"> - Up to 4 zones of dual channel active acoustics - Up to 8 zones of single channel active acoustics 									
	Description									
	<p>Dimensions : 8.9 x 48.3 x 22 cm (H x W x D) Weight: 3.2 Kg Shipping weight: 4.5 Kg Warranty: three year limited warranty on materials and workmanship from date of manufacture* * Sales of the product and liability are in accordance with the terms and conditions of sale</p>									
	References									
	<table border="1"> <thead> <tr> <th><u>Model</u></th> <th><u>Output</u></th> <th><u>Item number</u></th> </tr> </thead> <tbody> <tr> <td>D2001</td> <td>Digital</td> <td>6750</td> </tr> <tr> <td>A2001</td> <td>Analogue</td> <td>6751</td> </tr> </tbody> </table>	<u>Model</u>	<u>Output</u>	<u>Item number</u>	D2001	Digital	6750	A2001	Analogue	6751
<u>Model</u>	<u>Output</u>	<u>Item number</u>								
D2001	Digital	6750								
A2001	Analogue	6751								

AMPLIFIER D4100

Specifications	Amplifier features						
<p>Power:</p> <p>100 W per channel into 50 Ohms (70.7 V RMS) 50 Hz-15 KHz @ .1% THD all channels driven</p> <p>Frequency response: 20 Hz - 20 KHz (-3 dB)</p> <p>Distortion: 0.01% THD + N</p> <p>Input: AES/EBU X 2</p> <p>Digital communications to processor: Serial Data</p> <p>D/A converter: 24-bit Sigma Delta</p> <p>Power consumption: 50 VA Idle; 1100 VA peak</p>	<ul style="list-style-type: none"> - Two digital AES inputs (four independent channels) - Four 100 W, 70 V amplifier channels - Direct coupled high-voltage outputs - Control and monitoring of Amplifier by D2001 Processor - Up to two D4100 Amplifiers are controllable by one D2001 Processor - Industry-standard 2-part output connectors - Amplifier protected against overload, shorted output, internal failure - Status and problems reported back to D2001 Processor - Switching power supply for high efficiency - Universal power 100 V – 240 V autoswitching - Three U rack-mountable - CE marking 						
Description	References						
<p>Dimensions: 13.3 x 48.3 x 28.9 cm (H x W x D)</p> <p>Weight: 11,8 Kg</p> <p>Shipping weight: 14,0 Kg</p> <p>Warranty: three-year limited warranty on materials and workmanship from date of manufacture*</p> <p>* Sales of the product and liability are in accordance with the terms and conditions of sale</p>	<table border="1"> <thead> <tr> <th>Model</th> <th>Output</th> <th>Item number</th> </tr> </thead> <tbody> <tr> <td>D4100</td> <td>Digital</td> <td>6752</td> </tr> </tbody> </table>	Model	Output	Item number	D4100	Digital	6752
Model	Output	Item number					
D4100	Digital	6752					

HOW TO SELECT YOUR SOUND PANEL ?

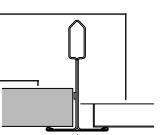
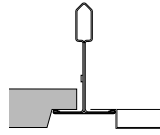
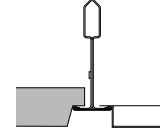
<p>Sound panel edge detail</p> <p>Ceiling edge detail</p> <p>Grid</p>  <p>Board visual where ceiling tiles and grids are at the same level</p>	 <p>Tegular visual for a ceiling with depth on a wide grid</p>	 <p>MicroLook visual for a ceiling with depth on a narrow grid</p>	
Sound panel edge detail	MicroLook	Tegular	MicroLook
Grid	24 mm	24 mm	15 mm

Please refer to the sound panel range for item numbers

United Kingdom
Republic of Ireland
 Armstrong World Industries Ltd
 Building Products Division
 Armstrong House
 38 Market Square
 Uxbridge UB8 1NG
 0800 371849 (UK) **FREEPHONE**
 Tel: 1800 409002 (ROI)
 Fax: 00 44 (0) 1895 274287
 www.i-ceilings.co.uk
 www.armstrong-ceilings.co.uk
 sales-support@armstrong.com

Armstrong World Industries Ltd
 5 The Village Centre
 Lucan
 Co Dublin

Please contact
 Internal Technical Sales
 for further details.

Armstrong